



BANJO MEASUREMENT FORM

instrument brand _____ model _____ year _____

CONTACT INFORMATION

date: _____

name: _____

phone: _____

email: _____

address: _____

COLOR OPTIONS

standard exterior:

- red blue burgundy
- green orange black
- gray yellow brown
- white

custom exterior: (additional charge)

- granite splatter sparkle

fill in custom color.. _____

interior velvet:

- red blue burgundy
- green black silver
- gold

backpack straps: (additional charge)

- black

MEASURING INSTRUCTIONS

STEP 1: Place the instrument on a table and rest the top tuning peg on a 1/2" block.

STEP 2: Take measurements to the nearest 1/16".

STEP 3: Make a tracing of the guitar body shape using a reasonable weight paper or light cardboard. It is important that this tracing is accurate to obtain a precise fit for your instrument.

STEP 4: Does your banjo have "Scruggs" style tuners or do you intend to install them? Please advise so we can alter the padding for them.

STEP 5: Note anything unusual about your banjo. Does it have external knobs, pickups, strap pins or anything else that requires special cutting of the padding? If so, please include the measurements for these items and note their exact placement on your tracing.

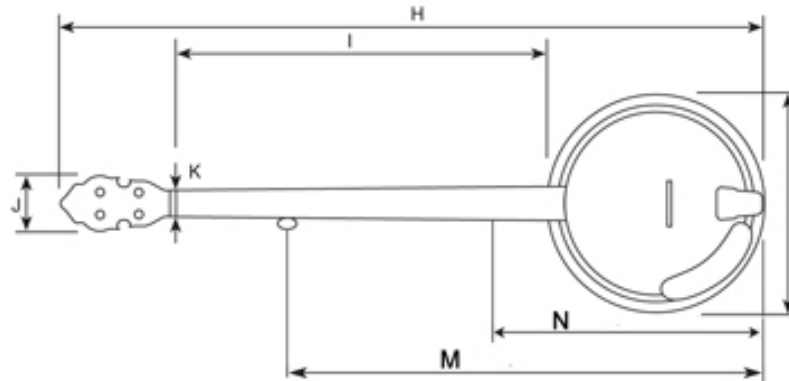
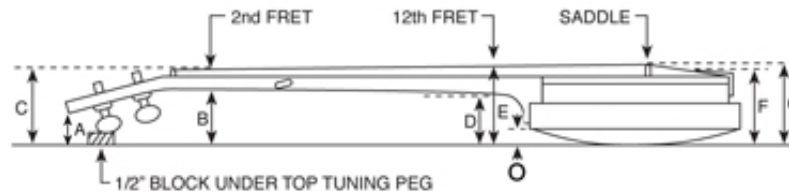

MEASUREMENTS

- _____ A - table to bottom of **headstock**
- _____ B - table to bottom of **neck** at **2nd fret**
- _____ C - table to top of **string** at **2nd fret**
- _____ D - table to bottom of **neck** at **12th fret**
- _____ E - table to top of **string** at **12th fret**
- _____ F - table to top of **body**
- _____ G - table to top of **bridge**
- _____ H - length of **banjo** (overall)
- _____ I - length of **neck** (Nut to Pot)
- _____ J - width of **headstock**
- _____ K - width of **neck** at **nut**
- _____ L - diameter of the **resonator** or the **pot** to the outside of the lugs (whichever is greater)
- _____ M - end of banjo to **5th string peg**
- _____ N - end of banjo to **balance point** (mostly for long neck banjos + non-resonators)
- _____ O - gap under **resonator**

dealer _____ measured by _____

send completed form to your authorized Calton Cases dealer. visit www.calton-cases.com/dealers/